

# ART-60-40-18-A3

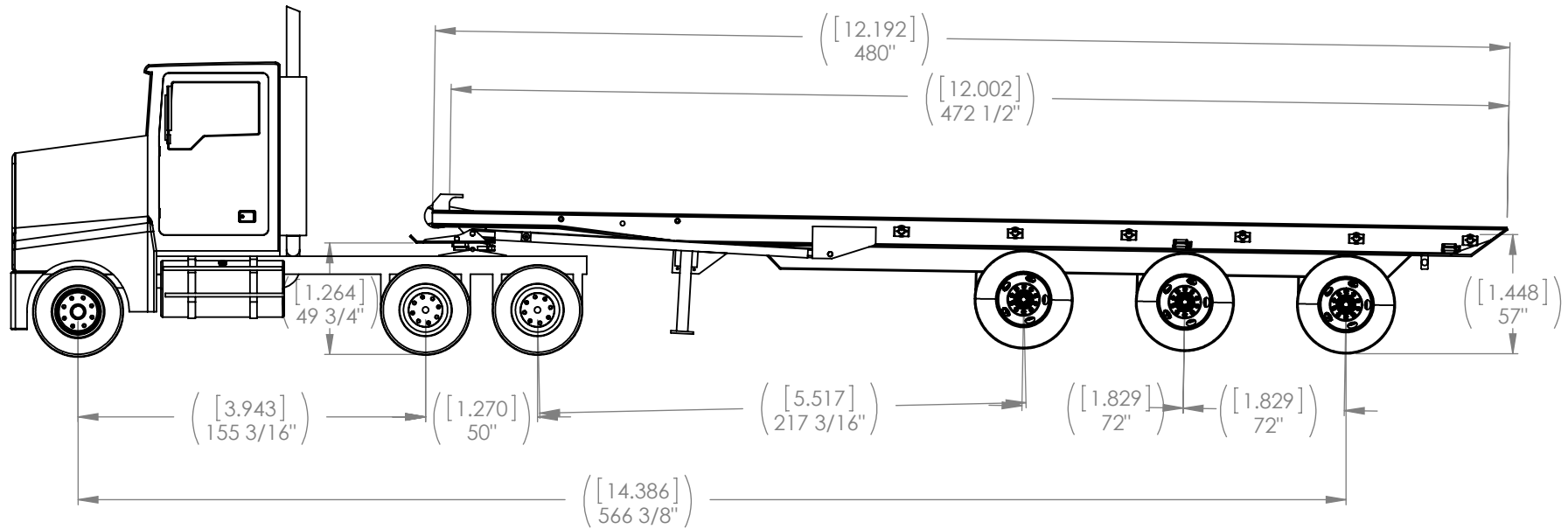

## Specification:

60,000# Capacity, Designed to Haul up to 40' Outside Rail Containers  
 12"x4"x3/8" Grade A Cross Members, 4"x4"x1/4" Stabilizer Frame  
 3/4" King Pin Plate, 3/8"x4" Flat Bar Wear Pad,  
 3-1/2" Shaft 7" Bore Reeve Cylinder (Duals)  
 8"- 4 Stage Telescopic Main Lift Cylinders (Duals)  
 7/8" IWRC Cable with 1" Ring  
 10" Main Pulley with Bronze Bushing

Tridem 30,000# Air Ride Suspension 72" axle spacing first axle lift rear axle  
 dump, 25,000# Axles  
 ABS Brakes, D.O.T Lights #108, fixed front stops  
 Rear Fenders Rubber on Tandem  
 ICC Regulated Bumper- Air Accuated  
 Manual outside controls with Air Control Brake  
 Color Industrial Enamel with Hardener (Black)

## Options:

Air Lift Fourth Axle	Hydraulic Tarp System
Aluminum Rims	In Cab Controls
Auto Grease System	Auto Tire Inflate System
Removable Stops	Disc Brakes

The information contained in this drawing is for illustrated purpose only, Brothers Equipment reserves the right to make changes at any time without notice.



## Brothers Equipment Inc.

1335 East 171st Street, Cleveland, Oh. 44110  
 800-578-8471 [www.brosequip.com](http://www.brosequip.com)



Brothers Equipment Inc.  
Cleveland, OH  
www.brothers-equipment.com  
800-378-8471

ACE  
EQUIPMENT CO.  
CLEVELAND, OH



ACE Brothers Equipment Inc.  
Cleveland, OH  
www.aceequipment.com  
800-378-6471

1

2

3